

The University of Jordan

Faculty of Engineering and Technology

Electrical Engineering Department

Measurements and Control Lab (EE 448)

Experiment 4: Electropneumatic Control Systems

Prepared by: Eng. Reem Al-Debes

Electropneumatic Control Systems

Objectives:

1. Familiarization with the Pneumatic system parts (cylinders, valves, timer, gates and memory).
2. Construct pneumatic control system to achieve any required performance.
3. Familiarization with the Electropneumatic system parts (sensors, relays and switches).
4. Construct electropneumatic control system to achieve any required performance.

Introduction:

The power supply in the electrical systems is a voltage signal, but the power supply in the pneumatic systems is a air signal. So, as we connect a voltage source to any electrical device to perform its work, we must connect air source to any pneumatic device to perform its work.

Let's explain the performance of each device in the pneumatic system to be able to construct complete control system.

A. Valves

There are different types of valves in the pneumatic kit, they are:

1. **3/2 directional Push-button with spring centering valve** (marked by # 1 on the practical kit)

It is showing in fig(1.1). The air source is connected to terminal 1, the output is connected to terminal 2 and the exhaust is terminal 3 (not connected).

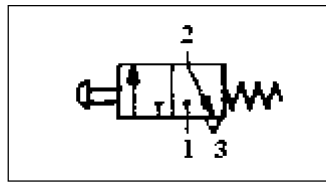

fig(1.1) 3/2 directional Push-button with spring centering valve

Its performance:

- a. The inactive position: the right chamber of the valve represents it. If the button is not pushed, the path from the source to the output is not available.
- b. The active position: the left chamber of the valve represents it. If the button is pushed, the path from the source to the output is now available (Imagine that the left chamber is pushed to replace the right one). When the button is reset, the spring will make the valve return to the inactive chamber, so the path from terminal 1 to terminal 2 will not be available anymore and the pipe air will be lost through the exhaust (terminal 3).

note: 3/2 valve means that number of chambers is 2 and number of (inputs + outputs) terminals are 3.

2. **5/2 directional Push-button with spring centering valve** (marked by # 2 on the practical kit)

It is showing in fig(1.2). The air source is connected to terminal 1, the first output is connected to terminal 2, the second output is connected to terminal 4 and the exhaust is terminal 3 and 5 (not connected).

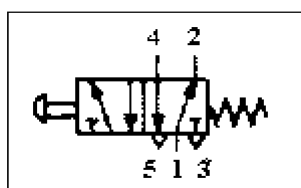

fig(1.1) 5/2 directional Push-button with spring centering valve

Its performance:

- a. The inactive position: the right chamber of the valve represents it. If the button is not pushed, the path from the source to the first output (terminal 2) is available and the air in any pipe connected to terminal 4 will release through exhaust (terminal 5).
- b. The active position: the left chamber of the valve represents it. If the button is pushed, the path from the source to the second output (terminal 4) is now available and the air in the pipe connected to terminal 2 will be lost through the exhaust (terminal 3) (Imagine that the left chamber is pushed to replace the right one). When the button is reset, the spring will make the valve returns to the inactive chamber, so the path from terminal 1 to terminal 2 will be available again and the air in the pipe connected to terminal 4 will be lost through the exhaust (terminal 5).

note: 5/2 valve means that number of chambers is 2 and number of (inputs + outputs) terminals are 5.

3. 3/2 directional pedal valve (marked by # 3 on the practical kit)

It is showing in fig(1.3). The air source is connected to terminal 1, the output is connected to terminal 2 and the exhaust is terminal 3 (not connected).

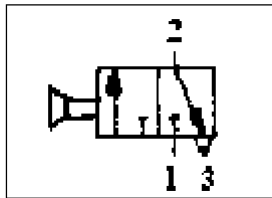

fig(1.3) 3/2 directional pedal valve

Its performance:

- a. The inactive position: the right chamber of the valve represents it. If the pedal is not pushed, the path from the source to the output is not available.
- b. The active position: the left chamber of the valve represents it. If the pedal is pulled, the path from the source to the output is now available. (Imagine that the left chamber is pushed to replace the right one).

There is no spring centering to return the valve automatically to the inactive position, so the pedal should push manually to return to the inactive position. In this case, the path from terminal 1 to terminal 2 will not be available anymore and the pipe air will be lost through the exhaust (terminal 3).

note: This valve could be used as an emergency valve.

4. 5/3 directional lever with spring centering valve (marked by # 4 on the practical kit)

It is showing in fig(1.4). The air source is connected to terminal 1, the output is connected to terminal 2 and terminal 4 and the exhaust is terminal 3 and 5 (not connected).

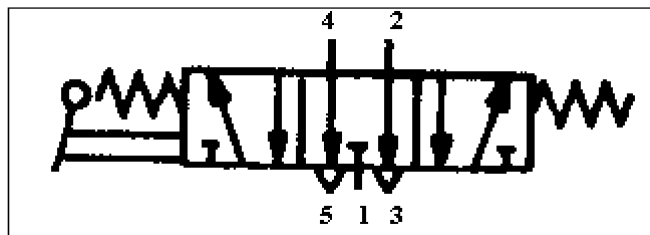

fig(1.4) 5/3 directional lever with spring centering valve

Its performance:

- a. The reset is represented by the middle chamber (no air flow from the source to any output)
- b. By turn the lever right; the right chamber is the active position and the air flows to terminal 2. If you release the lever, the valve returns by the spring automatically to the reset position. The air in the pipe connected to terminal 4 is lost through exhaust 5.
- c. By turn the lever left; the left chamber is the active position and the air flows to terminal 4. If you release the lever, the valve returns by the spring automatically to the reset position. The air in the pipe connected to terminal 2 is lost through exhaust 3.

5. **3/2 directional lever valve** (marked by # 5 on the practical kit)

It is showing in fig(1.5). The air source is connected to terminal 1, the output is connected to terminal 2 and the exhaust is terminal 3 (not connected).

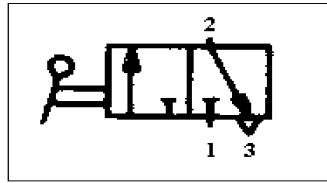

fig(1.5) 3/2 directional lever valve

Its performance is similar to 3/2 pedal valve but this one works with lever instead of pedal.

6. **3/2 directional roller valve** (marked by # 6 on the practical kit)

It is showing in fig(1.6). The air source is connected to terminal 1, the output is connected to terminal 2 and the exhaust is terminal 3 (not connected).

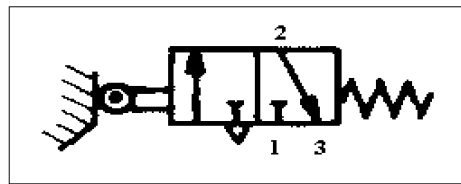

fig(1.6) 3/2 directional roller valve

Its performance is similar to 3/2 directional pushbutton valve but this one works with roller instead of pushbutton.

7. **3/2 directional plunger valve** (marked by # 7 on the practical kit)

It is showing in fig(1.7). The air source is connected to terminal 1, the output is connected to terminal 2 and the exhaust is terminal 3 (not connected).

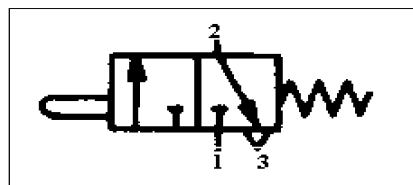

fig(1.7) 3/2 directional plunger valve

Its performance is similar to 3/2 directional pushbutton valve but this one works with plunger instead of pushbutton.

8. **Mono-stable indirect controller valve** (marked by # 8 on the practical kit)

It is showing in fig(1.8). The air source is connected directly (no need to connect it), the control signal is connected to terminal 14, the outputs are connected to terminals 2 and 4 and the exhaust is represented by terminal 3 and 5 (not connected).

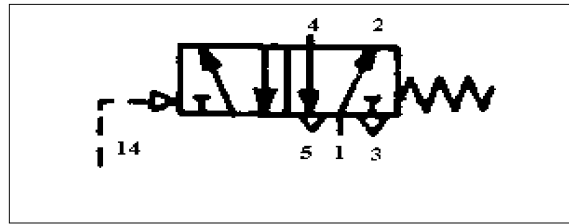

fig(1.8) 5/2 Mono-stable indirect controller valve

Its performance:

Assuming the air source is supplying the valve:

- If the pneumatic control signal x is OFF (no airflow): we get the inactive position (left chamber) and air will flow from the source to terminal 2. The air in the pipe connected to terminal 4 is lost through exhaust 5.
- If the pneumatic control signal x is ON: we get the active position (right chamber) and air will flow from the source to terminal 4. The air in the pipe connected to terminal 2 is lost through exhaust 3.

If a control signal applied the valve will return automatically to the inactive position by the spring.

note: we can describe this valve by the 2x1 De-Multiplexer.

9. **Bistable indirect controller valve** (marked by # 9 on the practical kit)

It is showing in fig(1.9). The air source is connected directly (no need to connect it), the two control signals are connected to terminals 12 and 14, the outputs are connected to terminals 2 and 4 and the exhaust is represented by terminal 3 and 5 (not connected).

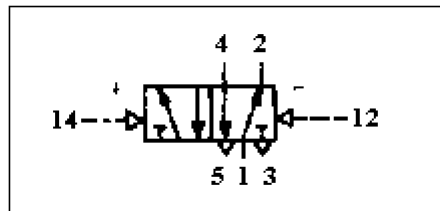

fig(1.9) Bistable indirect controller valve

Its performance:

Assuming the air source is supplying the valve:

- If the pneumatic control signals x_1 is OFF and x_2 is ON: we get the inactive position (left chamber) and air will flow from the source to terminal 2. The air in the pipe connected to terminal 4 is lost through exhaust 5.
- If the pneumatic control signals x_1 is ON and x_2 is OFF: we get the active position (right chamber) and air will flow from the source to terminal 4. The air in the pipe connected to terminal 2 is lost through exhaust 3.
- If both the pneumatic control signals are OFF or ON, equal air pressure will apply to both chambers and the position will stay as the previous one.

Note: the major difference between all valves and Bistable valves that the last one cause a continuous output flow of air when the control signal is ON.

10. Manual airflow regulator valve

It is shown in fig(1.10). We can manually control the airflow in the cylinder by adjustment this valve. So, we can control the speed of the moving of the cylinder by these valves.

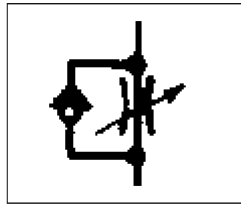

fig(1.10) Manual airflow regulator valve

B. Cylinders

The pneumatic kit contain 2 types of cylinders:

1. Single-acting cylinder

Single-acting cylinder is shown in fig(1.11).

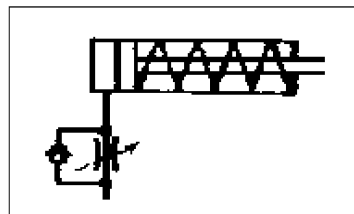

fig(1.11) Single-acting cylinder

When the air is pushed into this cylinder through the regulator valve, the cylinder will move forward under the pressure. And when the air inside the cylinder is released, the cylinder will move backward to the reset position.

2. Double –acting cylinder

Double-acting cylinder is shown in fig(1.12).

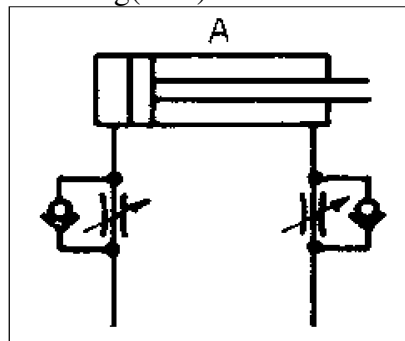

fig(1.12) Double-acting cylinder

When the air is pushed into this cylinder through the left regulator valve, the cylinder will move forward under the pressure. And when the air inside the cylinder is released and the air is pushed into this cylinder through the right regulator valve, the cylinder will move backward to the reset position.

If the air pressure is equal on both sides, the cylinder will not move to any direction and stay as it was.

C. Timer

The pneumatic kit contain one timer that can be used in 2 different ways as shown in fig(1.13).

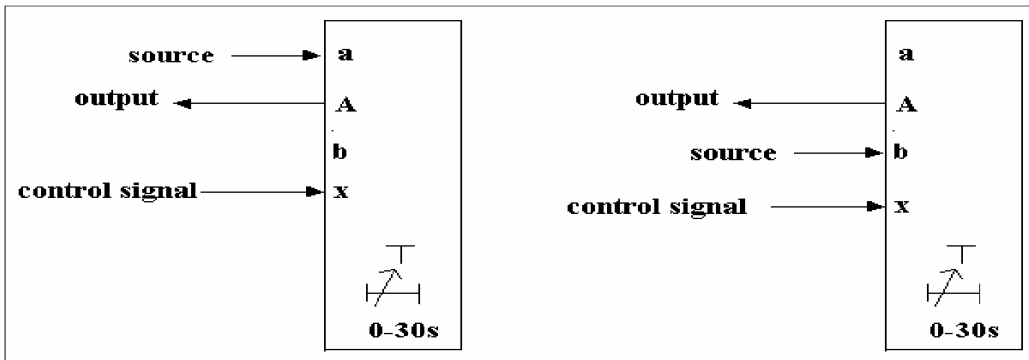

fig(1.13) a) NC timer , b) NO timer

a) NC timer

The control signal is connected to x terminal, the air source is connected to terminal a and the air path goes from the source to the output (A terminal), while terminal b is not connected. The time is graduated from 0-30s.

The path from the source to the output is normally closed (unavailable), but when the control signal becomes ON, the path will be open after T seconds.

b) NO timer

The control signal is connected to x terminal, the air source is connected to terminal b and the air path goes from the source to the output (A terminal), while terminal a is not connected. The time is graduated from 0-30s.

The path from the source to the output is normally open (available), but when the control signal becomes ON, the path will available after T seconds.

D. Logic Gates and Memory Cell

The pneumatic logic gates are similar to these in the electronic system. When the source supplying the gates, the output will be controlled by control signal (signals).

As an example, let's describe AND gate performance. Assume A and B are the control signals, the truth table of this gate is as shown in table(1.1).

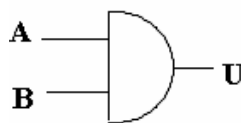

AND gate

Table(1.1)

A	B	U
0	0	0
0	1	0
1	0	0
1	1	1

So, the air will flow from the source to the output only and only if both control signals are ON. This application is used if we want to control load from two different positions together.

But if we want to control load from any one of two different positions, we have to use OR gate instead of the AND gate.

E. Solenoid Sensors

It translates the mechanical motion to electrical signal by produce an electrical pulse when the cylinder reaches the sensor position on the cylinder. They are connected on suitable holder on the cylinder in the required position (usually the start point and the end point to represent a0 and a1 respectively).

The other traducers are used to replace the air control signal of the monostable and bistable

valves by electrical control signals. They are connected in a specific position related to the monostable and bistable valves (no need to connect pipes to the input control signal sockets). So the valves are called "solenoid" valves instead of "pneumatic" valves.

note: See the appendix for the solenoid valves symbols.

D. Electronic Panel and contactors

The electronic panel unit is shown in fig(1.17). The solenoid cables from the cylinder are plugged on section E1 and the solenoid cables to the monostable and bistable valves are plugged on section E4.

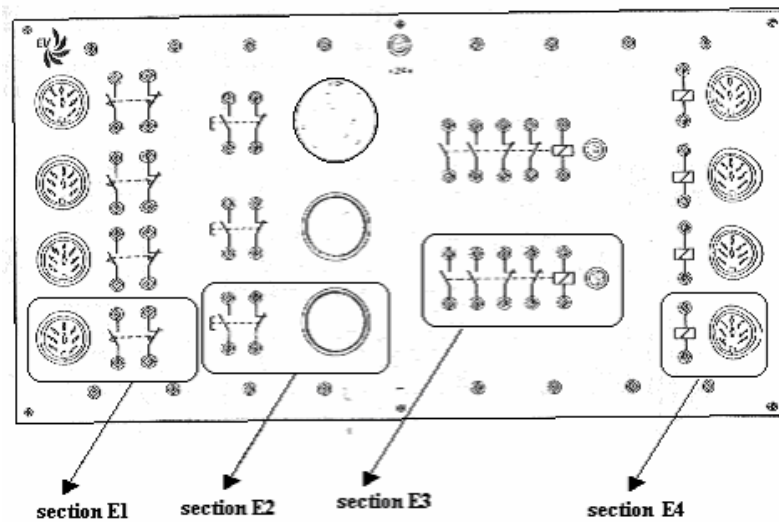

fig(1.17) Electronic panel

There are two types of contactors shown in section E1, section E2 and section E3: normally open (NO) and normally closed (NC). When they are activated, the switches change their situations (NO contactor becomes close and NC contactor becomes open).

When the moving cylinder reaching the position of the sensor that connected on it, the contactors in section E1 will be activated and their situations will change.

For more explanation, let's take the following example shown in fig(1.18).

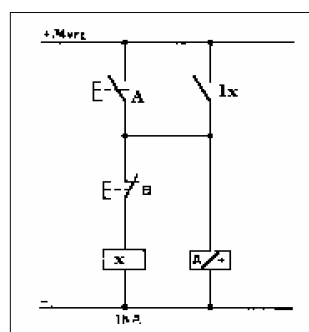

fig(1.18) example of electrical diagram

Connect NO contactor related to red pushbutton switch as A, and connect NC contactor related to black pushbutton switch as B. Then connect B in series with section E3. One NO contactor that is related to x is connected in series with section E4 (when x is activated, the NO contactor becomes close).

Procedure

Attention

Turn the Pneumatic Source OFF after each part of the experiment

Keep in mind: For valves; terminal #1 is marked by red dot on the valve, while terminal #2 is marked by (2) and the third plug is terminal #4 (if exist) is not marked. The exhaust has no visual metal terminal.

(1) Direct control of single-acting cylinder from two different locations

1. Construct the following pneumatic system (fig(1.19)).

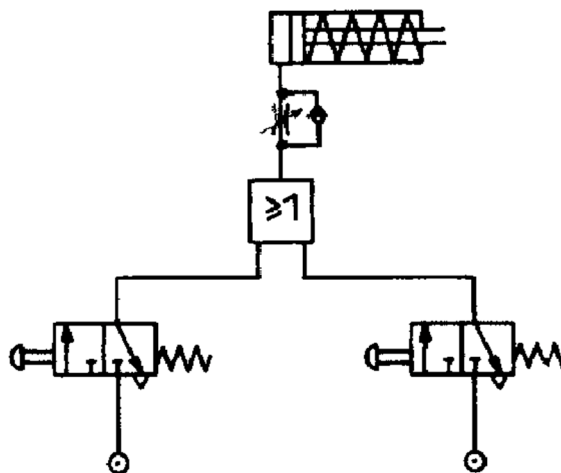

fig(1.19) A pneumatic system

2. Connect a0 to the red pneumatic light and a1 to the green pneumatic light.
3. Turn the pneumatic source ON.
4. Put the control signal (pushbutton inputs) according to following table and complete it in the same order.

x1	x2	OR gate output (expected)	a0	a1	Cylinder situation
0	0				
0	1				
0	0				
1	0				
0	0				
1	1				
0	0				

5. Explain what happened when you reset control signals $x1=x2=0$ after each step.

6. Slow down the flow air speed manually by the related valve and repeat the previous step. What do you notice?

(2) Indirect control of a double acting cylinder by a single pushbutton.

1. Construct the following pneumatic system (fig(1.20))(Use the double-acting cylinder on your right hand).

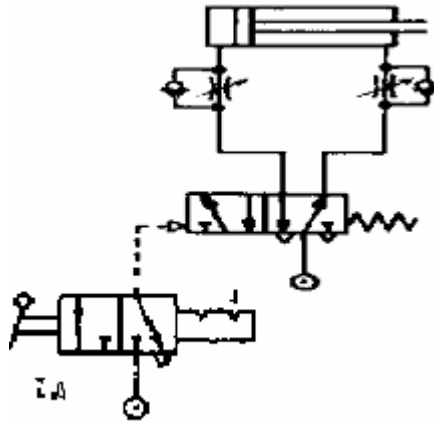

fig(1.20) A pneumatic system

2. Connect a0 to the red pneumatic light and a1 to the green pneumatic light.
3. Turn the pneumatic source ON.
4. Put the control signal (pushbutton inputs) x=1 then release it (x=0). Record the results in each situation in the following table.

x	a0	a1	Cylinder situation
1			
0			

5. Explain what happened.

(3) Semiautomatic control of double acting cylinder by a limit switch without and with Timed return

1. Construct the following pneumatic system (fig(1.21)).(Use the double-acting cylinder on your left hand).

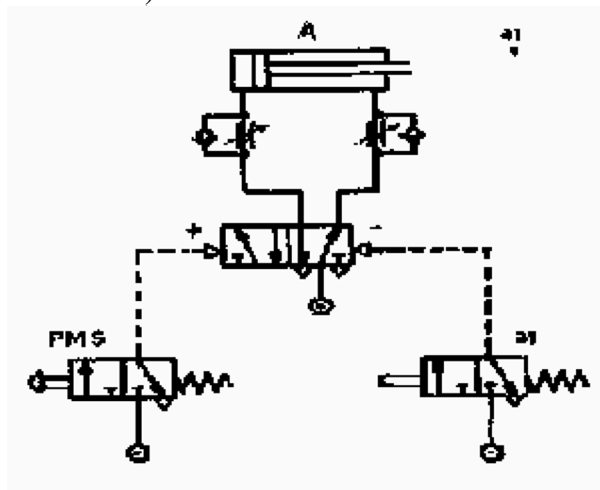

fig(1.21) A pneumatic system

2. Turn the pneumatic source ON.
3. Put the control signal (pushbutton inputs) (Primary Moving Switch (PMS)=1).
4. Explain what happen.

5. Turn the pneumatic source OFF.
6. Modify the previous control system as shown in fig(1.22). What do expect the mode of this timer should be? (NC or NO)

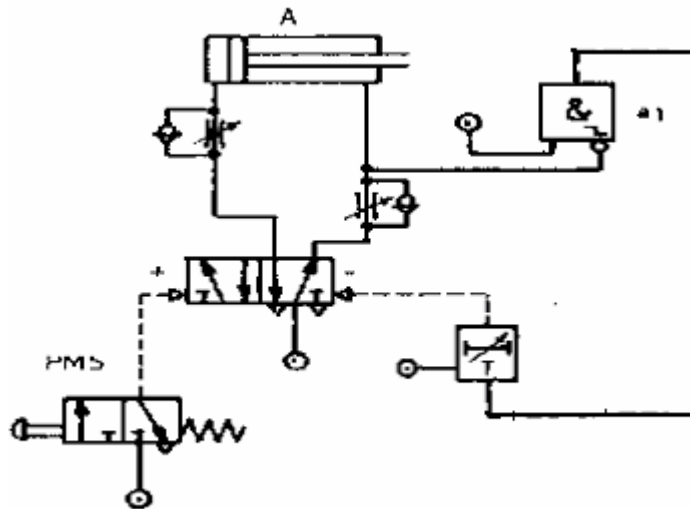

fig(1.22) timed return double acting cylinder

7. Set the timer at its middle point between 0 and 30 (about 15s).
8. Turn the pneumatic source ON.
9. Put the control signal (pushbutton inputs) (PMS=1).
10. Explain how this system works.

(4) A control System of two double acting cylinders

1. Construct the following pneumatic system (fig(1.24)). Notice that a0 should be 1 at the beginning of work.

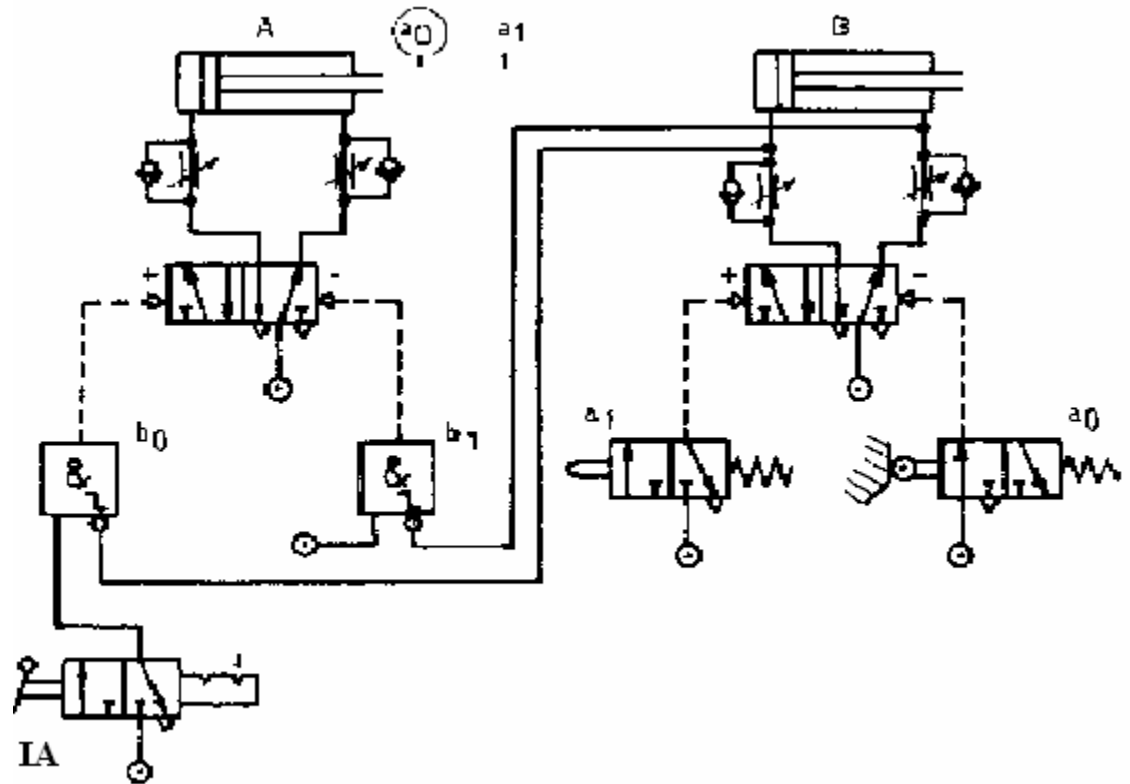

fig(1.24) A pneumatic control system of 2 double-acting cylinders

2. Slow down the airflow by all the related regulator valves so you could recognize the phases clearly.
3. Turn the pneumatic source ON.
4. Turn the lever switch ON.
5. Switch the lever control signal ON, and follow the work sequence (slow down the airflow so you can do it).

phase #	a0	a1	A	b0	b1	B
1						
2						
3						
4						
5						
6						

6. How many times the phases will be repeated? Explain why.

7. Turn the lever OFF. What will happen? Explain.

8. What will change if you replace the lever valve with pushbutton valve?

9. What is the effect of the initial value of a0 in this control design?

(5) Electronic control System

1. Construct the electronic control system shown in fig(1.25).

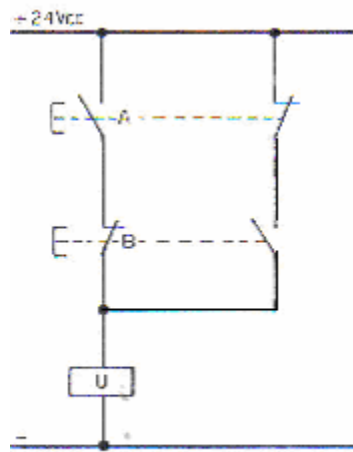

Electric diagram

fig(1.25)

2. Switch the power supply ON.

3. Activate the contactors according to the following table and complete it.

A	B	U
0	0	
0	1	
1	0	
1	1	

4. Situation the equivalent logic function of this logical control system.

U=

5. What is the equivalent logic gate of this function? -----

(6) Electropneumatic control System

I. First example

1. Connect sensor to double acting cylinder to represent a1 (at the end point).
2. Connect the sensor to monostable solenoid valves (A+)
3. Construct the Electropneumatic control System shown in fig(1.26).

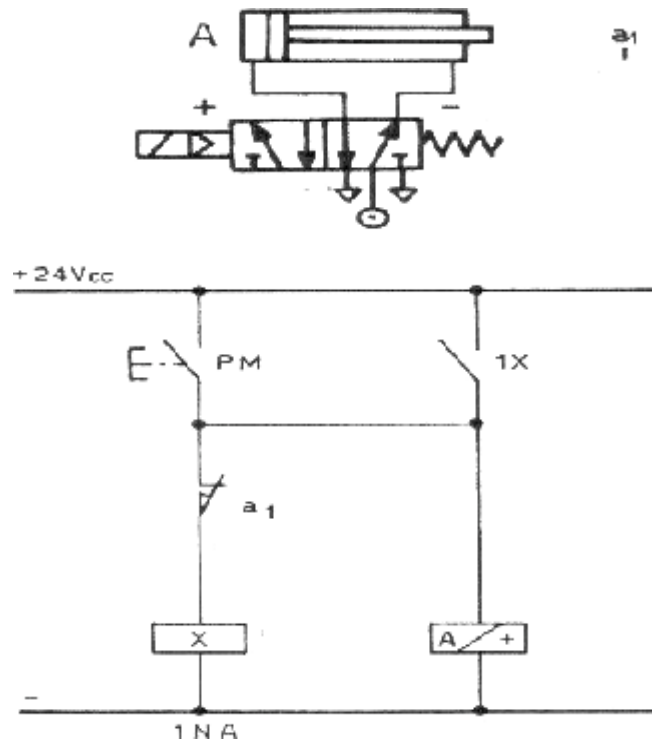

fig(1.26)

4. Push PM ON to start the system.
5. What is the state of a1 when you start?

6. Explain what happen to each part of the system at all phases

7. Turn the power supply OFF.

II. Second example

1. Connect sensors to represent a0, a1, b0 and b1. (at the beginning and the end of both cylinders respectively).
2. Connect the 4 sensors to two Bistable solenoid valves (A+, A-, B+ and B-)
3. Construct the Electropneumatic control system shown in fig(1.27).
4. Turn the pneumatic supply ON.
5. Turn the power supply ON.

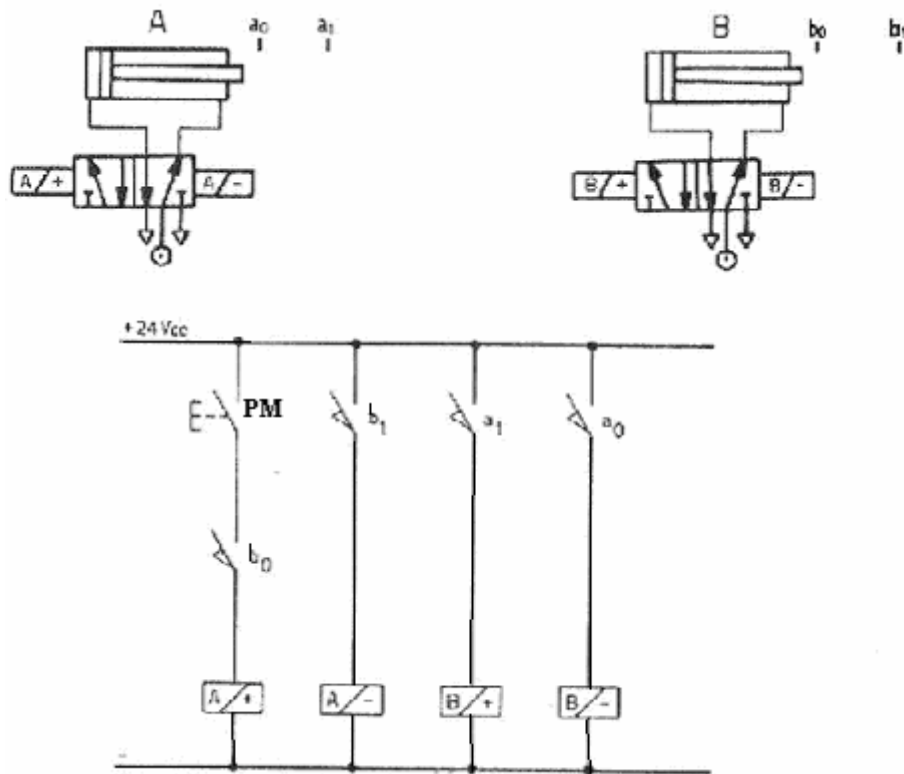











fig(1.27)

6. What is the initial value of a0, a1, b0 and b1?

7. Push PM ON to start the sequence.
8. Explain what happen to each part of the system at all phases

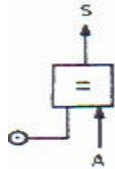
9. Turn both of the power supply and the pneumatic supply OFF.

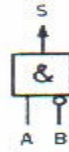
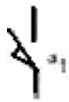
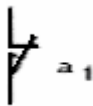
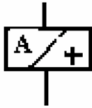
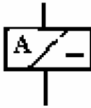
Appendix

Air source		OR gate	
Control signal line	----->	AND gate	
Airflow line direction		NOT gate	
Exhaust		YES gate	
Pneumatic light		Inhibition function gate	
solenoid NO contactor		Solenoid NC contactor	
Solenoid coil related to A+ situation		Solenoid coil related to A- situation	
Solenoid Monostable valve		Solenoid Bistable valve	
Cylinder A is moving forward	A+	Cylinder A is moving back	A-

a0 should be initially equal 1



Timer

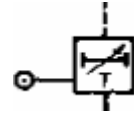

front view of monostable valve

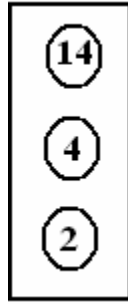

front view of bistable valve

